

Version:20130227

806DA INDICATOR MANUAL



ANYLOAD
www.load-cell.com

1. Introduction	1
1.1 Operation Modes.....	1
1.2 Front Panel Keypad	2
1.3 Indicating Lights	2
1.4 Start Up.....	2
1.5 Operations.....	3
1.5.1 Normal Weighing Mode.....	3
1.5.1.1 Gross/Net Mode	3
1.5.1.2 Zero Scale.....	3
1.5.1.3 Acquire Tare	3
1.5.1.4 Remove Stored Tare Value.....	3
1.5.2 Peak Mode Operations	3
1.5.2.1 Peak mode activated or deactivated	4
1.5.2.2 Zero Scale in Peak Mode	4
2. Wire Installation	5
2.1 AC power supply.....	5
2.2 Relay signal output.....	5
2.3 External switch interface.....	5
2.4 Load Cell Input.....	6
2.5 Switch J6	6
2.6 Serial Communication Port.....	6
3. Configuration	7
3.1 Front Panel Configuration.....	7
3.2 Menu Structure and Parameter Descriptions	8
3.2.1 F1(Configuration) Menu	9
3.2.2 F2 (Format) Menu	11
3.2.3 F3 (Calibration) Menu.....	12
3.2.4 F4 (Serial) Menu.....	13
3.2.5 F5 (Analog Cal) Menu	14
3.2.6 F6 (Relay) Menu	15
3.2.7 F7 (Ver) Menu.....	15
3.2.8 F8(Mode) Menu	16
4. Calibration	17
5. Analog output calibrate	19
6. Relay Output Setup	21
7. Serial Communication	25
7.1 Continuous Transmission.....	25
7.2 Transmission Upon Request	26
7.2.1 Data Transmission Sequence.....	26
7.2.2 Communication Command.....	27
7.2.2.1 Transmit Current Weight Value	27
7.2.2.2 Zero Scale.....	28
8. Appendix	29
8.1 Error Messages	29
8.2 Software Version and Default Configuration Parameters	29
8.2.1 Find out software version of indicator	29
8.2.2 Restore Factory Setup Parameters.....	30
8.3 Technical Specifications	31
8.4 ASCII Code table	32
8.5 806DA Display Characters	33

This manual provides the installation, operation, configuration and application information of indicator model 806DA. It's recommended to go through the manual in details before installing, operating or configuring the indicator.

1. Introduction

The 806DA weighing indicator is based on strain gauge load cell signal, 24-bit Σ - Δ type A/D conversion technology and 32-bit single chip microprocessor which is large scale integrated circuit, and is a kind of high precision, high reliability, multi-functional electronic weighing indicator.

Key features include:

- Parameter setting and calibration are performed at the front panel
- Optional auto zero scale when switching on
- Auto zero tracking
- Unit select between: kg, t
- Improper operation and fault indication
- Normal Weighing mode and Peak mode functions
- 2 way relay output
- 2-way external input switch interface
- Zero scale, Tare mode, Gross/Net weight selections
- Optional output interface: Standard serial output RS232 or RS485 interface;
Analog output interface;

Note: For the hardware configuration of output interface, the indicator can only have RS232 interface or RS485 interface; also for analog interface, there're 0~5V, 0~10V, and 4~20mA selectable, but only one configuration can be provided in one indicator.

1.1 Operation Modes

There are Weighing mode and Configuration mode.

- Weighing mode

Indicator will enter into weighing mode automatically after power on. According to F8 Menu, two weighing modes can be selected (refer to menu F8).

 - (1) Normal Weighing mode: Indicator displays gross weight or net weight in this mode. Unit of the displayed weight is highlighted by indicator light (refer to Section 1.5.1).
 - (2) Peak mode: Indicator displays peak value of load acted upon the weighing instrument (refer to Section 1.5.2).
- Configuration Mode

The operations such as parameter setting and calibration should be done in the Configuration Mode. Enter into the Configuration Mode as follows:

Press **【SET】** and **【G/N】** buttons, the indicator will enter into Configuration Mode, and the display shows "F 1". Refer to Section 3 for details.

1.2 Front Panel Keypad

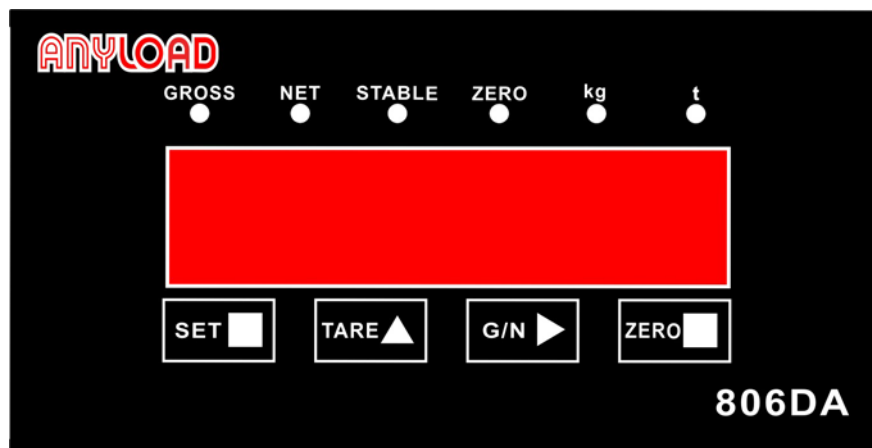

Fig.1-1 Front Panel

Fig.1-1 shows indicator display, LED lights and the keypad layout. To use these buttons in different modes, please refer to Section 3 for details.

1.3 Indicating Lights

- “kg”—— Light is on when display showing unit in kilogram.
- “t”——Light is on when display showing unit in tonne.
- “GROSS”—— Light is on when display showing gross weight.
- “NET”——Light is on when display showing net weight.
- “STABLE”—— Light is on when load is stable or within the preset dynamic load range. Zero scale, Tare Store/Remove operation must be done in the stable status. Please refer to Menu F1.4 for the configuration of dynamic range.
- “ZERO”—— Light is on when load is within zero range($<1/4d$) .

1.4 Start Up

Connect the power supply. Indicator goes through a self-checking process (showing all 0 to all 9). Two possible outcomes according to the configuration of Menu F1.12:

- If indicator is set to Auto Zero Scale (F1.12=0), and the load on the scale is within the zero scale range setting in Menu F1.3, display shows zero.
- If indicator is not set to Auto Zero Scale (F1.12=1) or the load exceeds the zero range setting in Menu F1.3, display shows actual load.

Refer to Menu F1.3 and F1.12 for further information.

1.5 Operations

Indicator enters into Weighing Mode automatically after power on. According to the configuration of Menu F8, it can be selected to normal Weighing Mode or Peak Mode (refer to Menu F8).

1.5.1 Normal Weighing Mode

Basic Operations in Normal Weighing Mode:

1.5.1.1 Gross/Net Mode

When tare weight is stored, press **【G/N】** button, the display will change to net weight from gross weight or vice versa. If the tare weight stored is other than 0, net weight shown on the display is equal to gross weight less tare weight.

- Tare weight stored: “GROSS” light is on when display shows gross weight.
“NET” light is on when display shows net weight.
- No Tare weight stored: Both “GROSS” and “NET” lights are off.

1.5.1.2 Zero Scale

When the “GROSS” light is on or there’s no tare weight is stored (both “GROSS” and “NET” lights are off), remove the load from scale and wait until the “STABLE” light is on. Press **【ZERO】** and “ZERO” light is on. Zero Scale setting is complete.

1.5.1.3 Acquire Tare

When no tare weight is stored (both “GROSS” and “NET” lights are off), place the container on the scale and wait until the “STABLE” light is on. Press **【TARE】**, tare weight is stored. Display shows Net weight while “NET” light is on.

1.5.1.4 Remove Stored Tare Value

When a tare weight is stored (either “GROSS” or “NET” light is on), press **【TARE】** to remove the stored tare value. When there’s no tare weight stored both the “GROSS” and “NET” lights are off.

1.5.2 Peak Mode Operations

When set the parameter F8.1=1 and, F8.2=2 or F8.3=2, the indicator is set to Peak Mode

(refer to F8 Menu setting).

Basic operations when in Peak mode:

1.5.2.1 Peak mode activated or deactivated

When F8.1=1 and, F8.2=2(External switch interface 1 is connected) or F8.3=2(External switch interface 2 is connected), press down the External switch, the Peak mode function is activated; press the External switch again, and the Peak mode function is deactivated. When in Peak mode is activated, display shows the maximum value of load which has been applied to the load cell. When the load is removed, display will show the peak load.

When F8.1=0, the Peak mode function is inhibited. Indicator is in normal weighing mode.

1.5.2.2 Zero Scale in Peak Mode

When F8.1=1, and Peak mode function is deactivated, also the “STABLE” light is on, press **【ZERO】**, the display shows zero.

When F8.1=1, and Peak mode function is activated, **【ZERO】** is inhibited.

2. Wire Installation

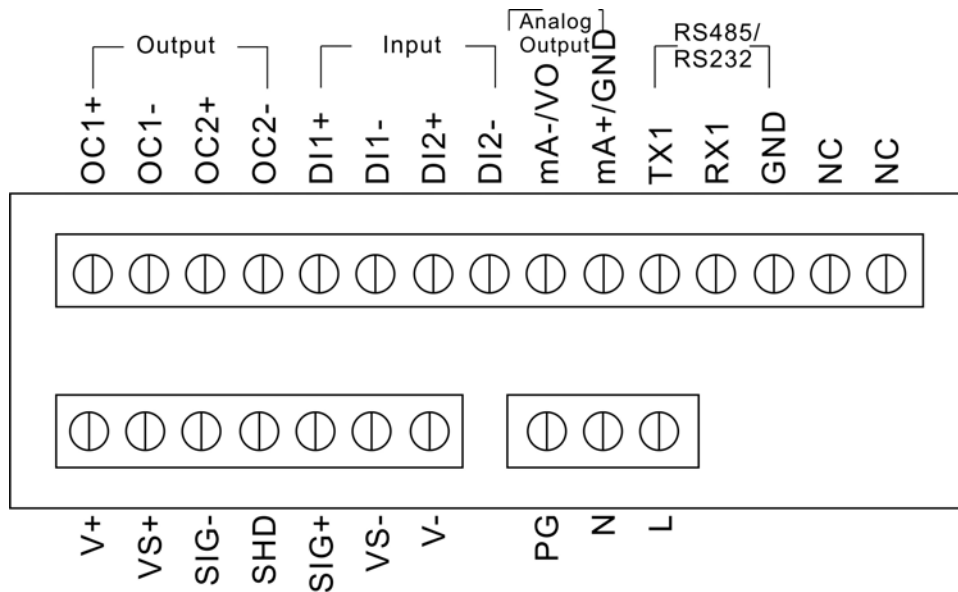

Fig.2-1 Sockets on the back of indicator

2.1 AC power supply

PG — GND; L — AC; N — AC; (100-240VAC /1A)

2.2 Relay signal output

Low limit control output — OC1+, OC1-; High limit control output — OC2+, OC2-;

2.3 External switch interface

External switch interface 1 — DI1+, DI1-;

External switch interface 2 — DI2+, DI2-;

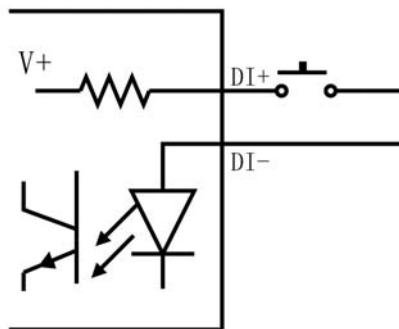

Fig.2-2 External interface connecting diagram

2.4 Load Cell Input

- (V+)—— Excitation+
- (VS+)—— Sense+
- (SIG-)—— Signal-
- (SHD)—— Signal Ground
- (SIG+)—— Signal+
- (VS-)—— Sense-
- (V-)—— Excitation-

2.5 Switch J6

When the indicator connected to 4-wire Load cell, please turn on the switch J6; otherwise, when connected to 6-wire load cell, turn off the switch.

2.6 Serial Communication Port

- (RX1)—— RS232/RS485 Receipt port
- (TX1)—— RS232/RS485 Send port
- (GND)—— Signal Ground (connect to computer)
- NC—— No connection
- NC—— No connection

3. Configuration

Configure indicator according to the following steps:

- Press down the **【SET】** and **【G/N】** buttons on the front panel at the same time.
- Indicator now is in Configuration mode and display shows “F 1” in the first menu item of Level 1 submenu. The Level 1 submenu consists of 8 menu items, after configuration, when indicator return to the Level 1 submenu, press **【SET】** button to exit from configuration mode.

3.1 Front Panel Configuration

When configuring, keypad functions as shown in Fig. 3-1.

Table 3-1 Basic functions of Level 1 Submenu

Menu	Menu Function
F1	Set grads, zero tracking range, zero range, motion brand, overload range, sample rate, digital filtering and power up zero. See section 3.2.1.
F2	Set decimal point location, display divisions, display rate. See section 3.2.2.
F3	Calibrate indicator. See section 3.2.3 and section 4.
F4	Configure serial communication ports. See section 3.2.4 and section 7.
F5	Analog output calibrate. See section 3.2.5 and section 5.
F6	Set relay operation modes. See section 3.2.6 and section 6.
F7	Indicate software version and regenerate default configuration parameters. See section 3.2.7 and Appendix 8.2.
F8	External switch interface. See section 3.2.8.

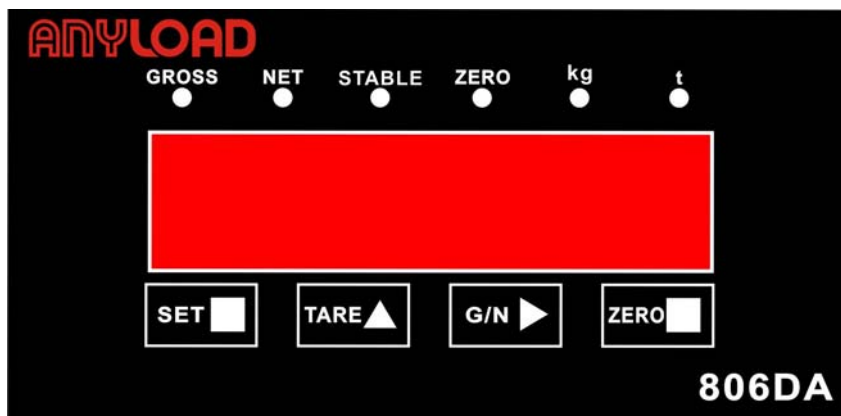

Fig.3-1 Keypad functions in Configuration Mode

3.2 Menu Structure and Parameter Descriptions

Menu structure is shown in the following section in flow diagram. In the actual Menu structure, the selected menu item is displayed horizontally. In most menus, set parameters and parameter value are shown in tables. Choices with “√” are default values, and “number” is editable values.

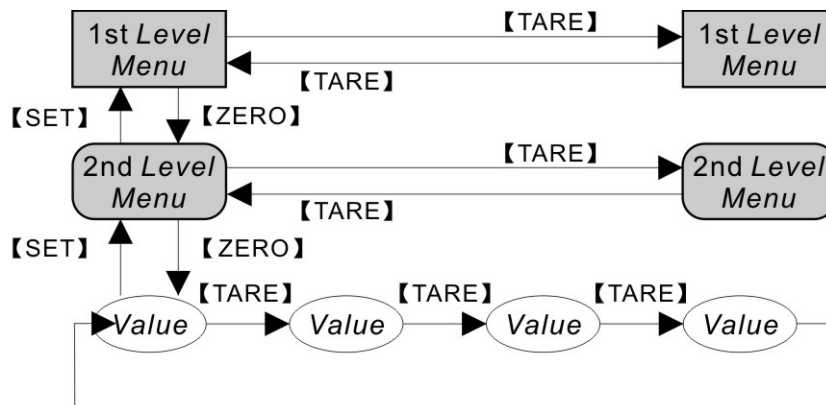

Fig. 3-2 Menu Configuration Flow Diagram

There are two directional keys **【G/N】**, **【TARE】** to be used for configuration operation. **【ZERO】** is for moving into a parameter of a menu and confirming a choice.

To set a parameter in the menu, use **【TARE】** to move horizontally in the same level menu, when the display shows the right menu you want to move into, press **【ZERO】**.

When moving into a parameter of a menu, display shows the previous stored value.

When the parameter of a menu is a fixed value, use **【TARE】** to move horizontally and use **【ZERO】** to store the selected parameter then return to the last menu.

When a parameter value of a menu is editable as shown in Fig. 3-3, **【G/N】** is used to move the selection of digit, and **【TARE】** is used to increase the value of the selected digit.



Fig. 3-3 Editable Parameter

When editing the number, the selected digit will flash, use **【G/N】** to change the selection of digit. Press **【TARE】** to increase the value of the selected digit. When finished, press **【ZERO】** to save the value then go to the next menu.

3.2.1 F1(Configuration) Menu

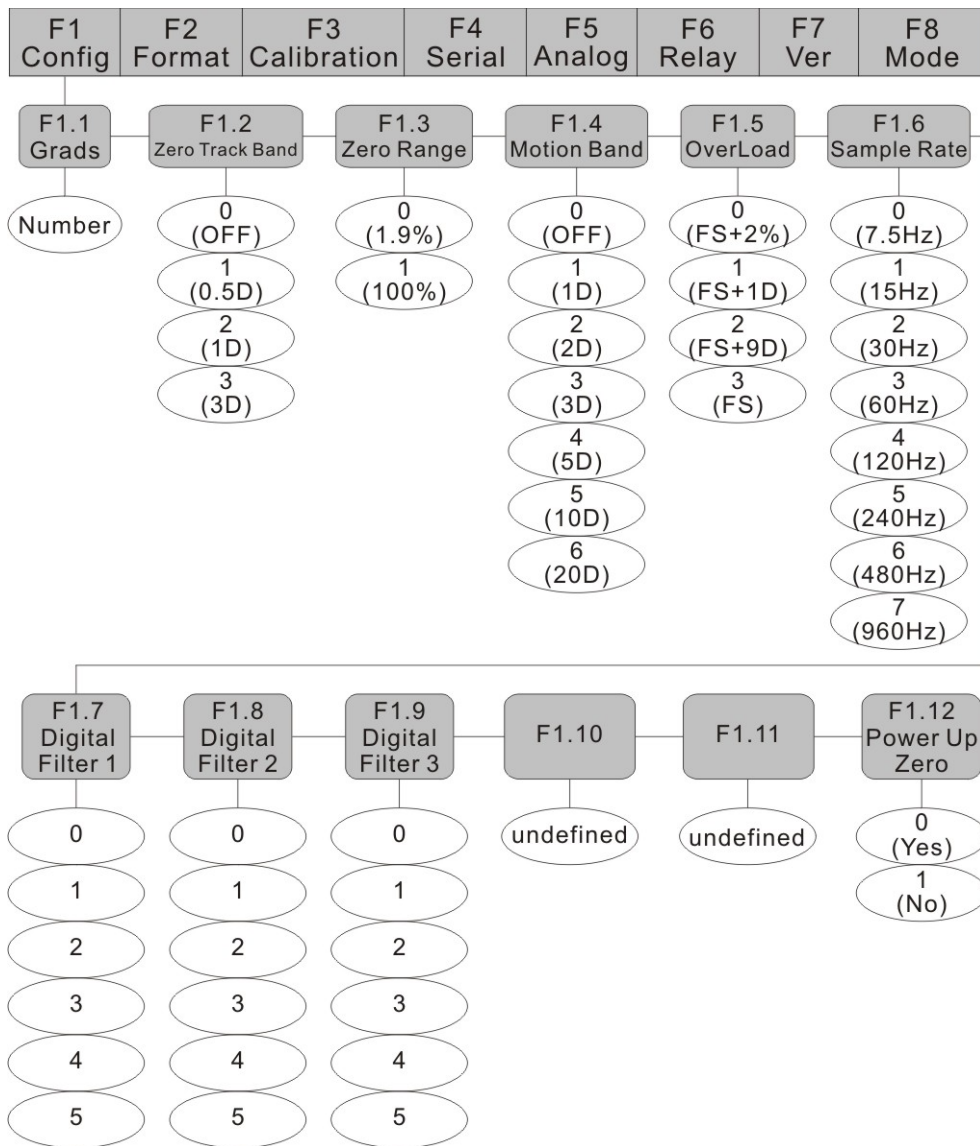

Fig. 3-4 F1 (Configuration) Menu Structure

Table 3-2 F1(Configuration) Menu Parameters

F1(Configuration) Menu		
Parameter	Choices	Description
Level 2 Submenu		

F1.1 (Grads)	number	Graduations. Graduation=Capacity/Display divisions. Display divisions is specified in the F2 (Format) Menu.
F1.2 (Zero track band)	0(OFF)	Zero track range.
	1(0.5D) ✓	Automatically zeros the scale when within the range specified.
	2(1D)	Selections are \pm display divisions.
	3(3D)	
F1.3 (Zero range)	0(1.9%FS) ✓	Zero range.
	1(100%FS)	Selects the range within which the scale can be zeroed. The 1.9%FS selection is \pm 1.9% around the calibrated zero point, for a total range of a 3.8%FS. FS=Grads*D
F1.4 (Motion band)	0(OFF)	Motion band.
	1(1D)	Sets the level in display divisions at which scale motion is detected. If motion is not detected for 1 second or more, the "Stable" light is on. Some operations, including Zero and Tare, require the scale to be at standstill. When F1.4 is selected OFF, F1.2 should also be set to OFF.
	2(2D) ✓	
	3(3D)	
	4(5D)	
	5(10D)	
	6(20D)	
F1.5 (Overload)	0 (FS+2%)	Overload.
	1 (FS+1D)	Determines the point at which the display shows "OF" indicating the scale is overloaded.
	2 (FS+9D) ✓	
	3 (FS)	
F1.6 (Sample rate)	0 (7.5Hz)	Sample rate.
	1 (15Hz) ✓	Selects the measurement rate in samples per second of the analogue-to-digital converter. Lower sample rate values provide greater signal noise immunity.
	2 (30Hz)	
	3 (60Hz)	
	4 (120Hz)	
	5 (240Hz)	
	6 (480Hz)	
	7 (960Hz)	
F1.7 (Digital Filter 1)	0 ✓	Digital Filter.
	1	Selects the digital filtering rate. The higher the value, the lower is the effect acting upon the indicator due to noise and mechanical vibration and hence having a more accurate display. However, it slows down the settling rate of the indicator.
	2	
	3	
	4	
	5	
F1.8	0	

(Digital Filter 2)	1 ✓	
	2	
	3	
	4	
	5	
F1.9 (Digital Filter 3)	0	
	1 ✓	
	2	
	3	
	4	
	5	
F1.10		Undefined
F1.11		Undefined
F1.12 (Power up zero)	0 (Yes)	Power Up Zero. Specifies whether to zero the scale when switching on the indicator. When selected 0 (Yes), indicator zeros the scale after finishing self checking.
	1 (No) ✓	

3.2.2 F2 (Format) Menu

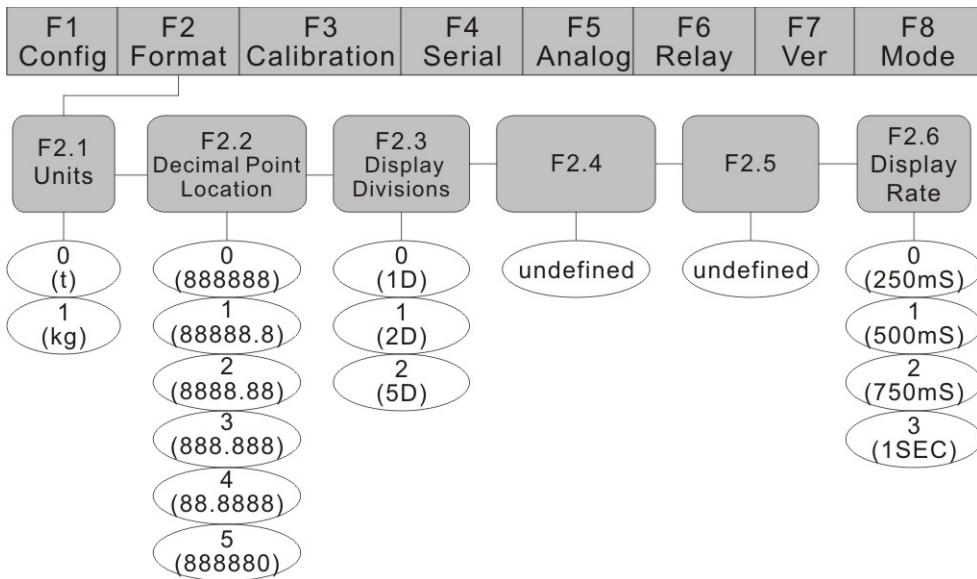

Fig. 3-5 F2 (Format) Menu

Table 3-3 F2(Format) Menu

F2(Format) Menu		
Parameter	Choices	Description
Level 2 submenu		
F2.1 (Unit)	0(t)	Unit Select the display unit and the calibration process will be done according to the selected unit.
	1(kg) ✓	
F2.2 (Decimal point location)	0(888888)	Specifies the decimal position of the unit.
	1(88888.8) ✓	
	2(8888.88)	
	3(888.888)	
	4(88.8888)	
	5(888880)	
F2.3 (Display division)	0(1) ✓	Specifies the display divisions of the unit.
	1(2)	
	2(5)	
F2.4		Undefined.
F2.5		Undefined.
F2.6 (Display rate)	0(250ms)	Sets the update rate for displayed values. Values are in milliseconds (ms) or seconds (s).
	1(500ms) ✓	
	2(750ms)	
	3(1s)	

3.2.3 F3 (Calibration) Menu

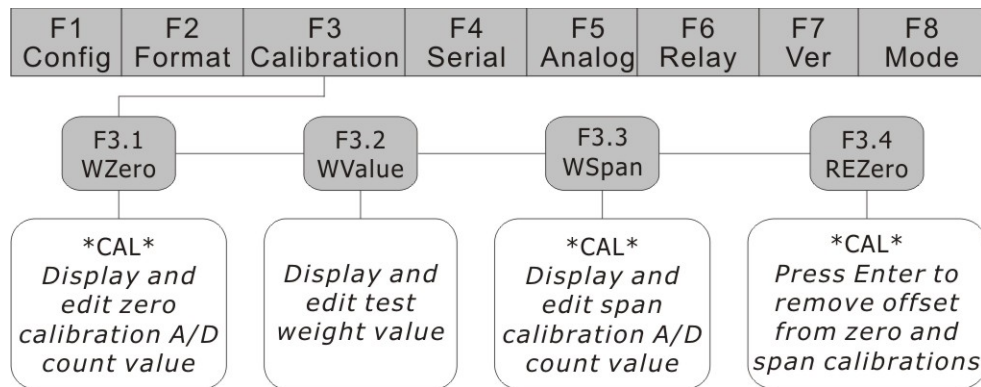

Fig.3-6 F3 Calibration Menu

Table 3-4 F3(Calibration) Menu

F3(Calibration) Menu		
Parameter	Choices	Description
Level 2 Submenu		
F3.1 (WZero)	—	Display the zero calibration A/D count value. Can not edit this value. Refer to Section 4.
F3.2 (WValue)	—	Display and edit the test weight value, the value entered must above 000100. Refer to Section 4.
F3.3 (WSpan)	—	Display the span calibration A/D count value. Refer to Section 4.
F3.4 (REZero)	—	Press 【ZERO】 to remove an offset value from the zero and span calibration. Use this parameter only after F3.1 (WZero) and F3.3 (WSpan) have been set. Refer to Section 4.

3.2.4 F4 (Serial) Menu

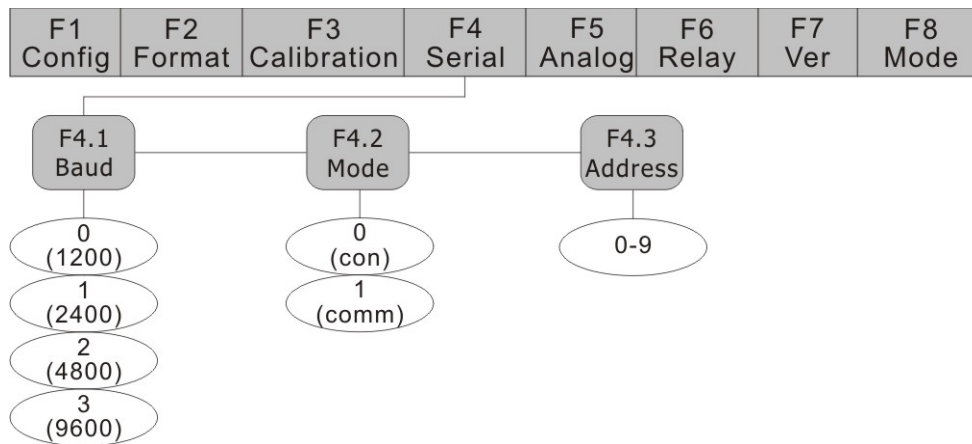

Fig.3-7 F4 (Serial) Menu

Table 3-5 F4 (Serial) Menu

F4 (Serial) Menu		
Parameter	Choices	Description
Level 2 Submenu		
F4.1 (Baud rate)	0(1200)	Specifies baud rate setting for serial communication. (8 data bits, no parity, 1 stop bit)
	1(2400)	
	2(4800)	
	3(9600) ✓	

F4.2 (Mode)	0(con)	Selects the mode of data transmission. 0(con) is for continuous transmission and 1(comm) is for transmission upon receiving commands. Refer to Section 7.
	1(comm) ✓	
F4.3 (Address)	0-9	Transmission address(1-9)

3.2.5 F5 (Analog Cal) Menu

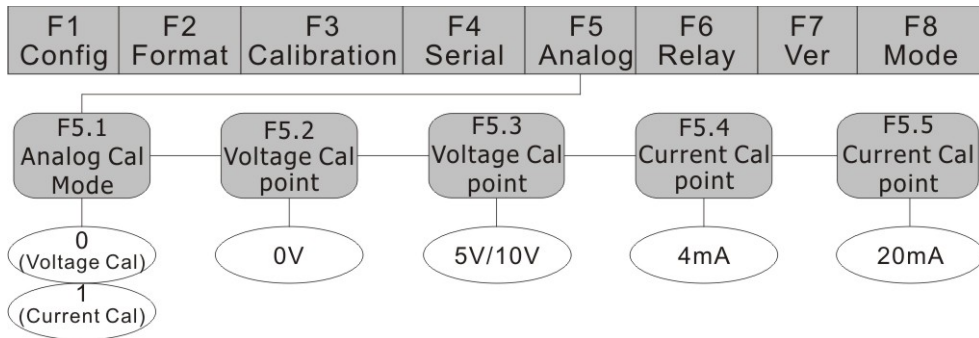

Fig.3-8 F5 (Analog Cal) Menu

Table 3-6 F5(Analog Cal) Menu

F5(Analog Cal) Menu		
Parameter	Choices	Description
Level 2 Submenu		
F5.1 (Analog Cal mode)	0(Voltage calibrate) ✓	Analog output calibrate mode.
	1(Current calibrate)	
F5.2 (Voltage Cal point)	—	0V
F5.3 (Voltage Cal point)	—	5/10V
F5.4 (Current Cal point)	—	4mA
F5.5 (Current Cal point)	—	20mA

3.2.6 F6 (Relay) Menu

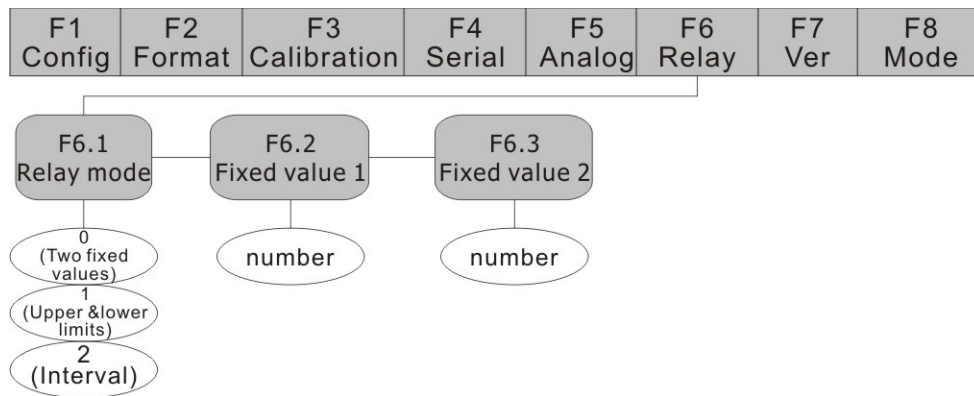

Fig.3-9 F6 (Relay) Menu

Table 3-7 F6 (Relay) Menu

F6(Relay) Menu		
Parameter	Choices	Description
Level 2 Submenu		
F6.1 (Mode)	0(Two fixed values)	Select the relay output mode. See section 5.
	1(Upper and lower limits)	
	2(Interval) ✓	
F6.2 (Fixed value 1)	Number	Specifies fixed value 1. Refer to Section 6 for Relay Output setup.
F6.3 (Fixed value 2)	Number	Specifies fixed value 2. Refer to Section 6 for Relay Output setup.

3.2.7 F7 (Ver) Menu

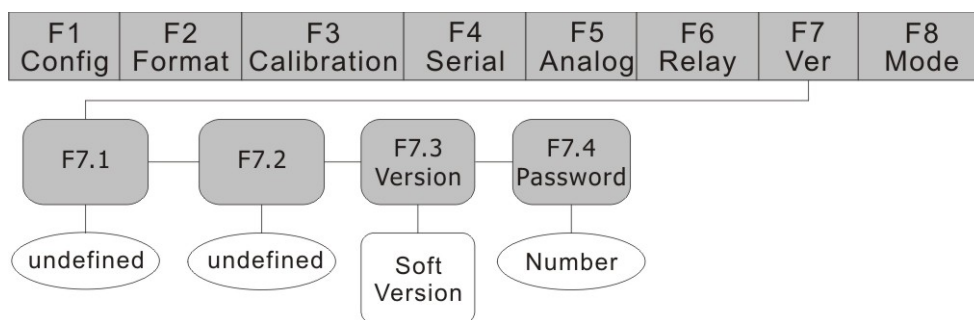

Fig.3-10 F7(Ver) Menu
15

Table 3-8 F7(Ver) Menu

F7(Ver) Menu		
Parameter	Choices	Description
Level 2 Submenu		
F7.1		Undefined
F7.2		Undefined
F7.3	Soft Version	Displays the software version installed in the indicator. This value cannot be altered.
F7.4	Number	Press 【ZERO】 after inputting the Password to recover the default value in the ROM. Refer to Appendix 8.2.2.

3.2.8 F8(Mode) Menu

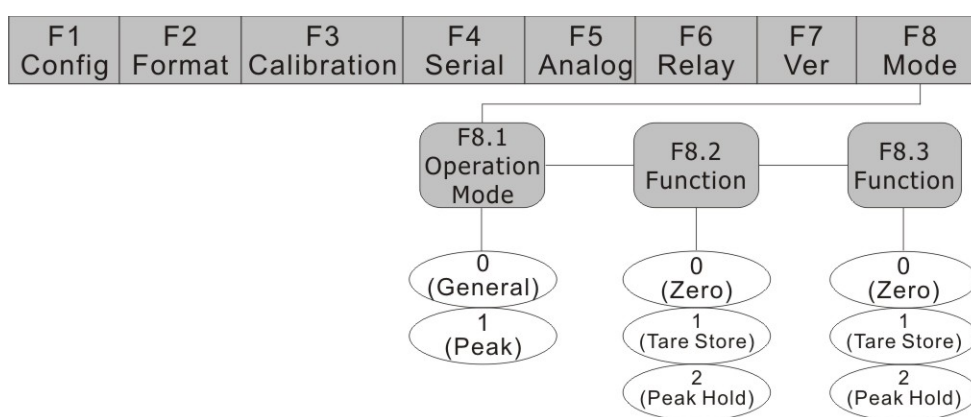

Fig.3-11 F8 (Mode) Menu

Table 3-9 F8(Mode) Menu

F8(Mode) Menu		
Parameter	Choices	Description
Level 2 Submenu		
F8.1 (Mode)	0(General) ✓	Select the operation mode.
	1(Peak)	
F8.2 (Function)	0(Zero) ✓	Function selection for external connection.
	1(Tare store)	
	2(Peak hold)	
F8.3 (Function)	0(Zero) ✓	Function selection for external connection.
	1(Tare store)	
	2(Peak hold)	

F8 Menu is used to set for weighing mode and external input function.

4. Calibration

The calibration of 806DA consists of the following steps:

- Zero calibration
- Entering the test weight value
- Span calibration
- Optional re-zero calibration for test weights using hooks or chains.

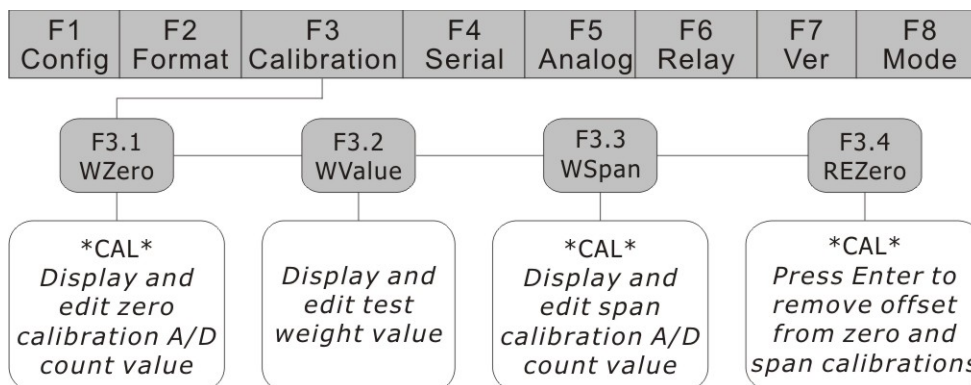

Fig.4-1 F3(Calibration) Menu

The following section describes calibration procedure for details:

- 1) Set indicator to the Configuration mode (display shows "F 1") and remove all weight from the scale platform. If the test weights require hooks or chains, place the hooks or chains on the scale for zero calibration.
- 2) Press **【TARE】** until the display shows "F 3" (see Fig. 4-1). Press **【ZERO】** to go to zero calibration mode. Display shows "F 3.1".
- 3) When the display shows "F 3.1", press **【ZERO】** to zero calibration. Display shows "CAL" while calibration is in progress. When completed, the A/D count for the zero calibration is displayed. Do not adjust this value. Press **【ZERO】** again to save the zero calibration value and go to the next menu (display shows "F 3.2").
- 4) When display shows "F 3.2", place test weight on the scale and press **【ZERO】** to show the test weight value. Follow Fig. 4-2 to input the test weight value, then press **【ZERO】** to save the value and go to the next menu. Display shows "F 3.3".
- 5) When display shows "F 3.3", press **【ZERO】** to calibrate span. Display shows "CAL" while calibration is in progress. When completed, the A/D count for the span calibration is shown. Do not adjust this value. Press **【ZERO】** again to save the span calibration value and go to the next menu. Display shows "F 3.4".
- 6) F 3.4 Menu is used to remove a calibration offset when hooks or chains are used to hang the test weights.

When display shows “F3.4”, there are 2 options:

- If no other apparatus is used to hang the test weights during calibration, remove the test weight and press **【SET】** to return to F3 Menu. Display shows “F 3”.
- If hooks or chains are used during calibration, remove these and the test weights from the scale. With all weight removed, press **【ZERO】** to re-zero the scale. This function adjusts the zero and span calibration values. Display shows “CAL” while zero and span calibrations are adjusted. When complete, the adjusted A/D count for the zero calibration is shown. Press **【ZERO】** to save the value and to return to F4.1 Menu. Display shows “F4.1”.

7) Press **【SET】** twice to exit from the configuration mode.



Fig. 4-2 Editing Procedure for Numerical Values

When editing numerical values, press **【G/N】** to change the digit selected. Press **【TARE】** to increase or decrease the value of the selected digit. Press **【ZERO】** to save the selected parameter and go to the next menu.

5. Analog output calibrate

There are options to choose from voltage (0-5V or 0-10V) or current (4-20mA) calibrate for analog output of the 806DA. Only calibrate by one of them is enough.

806DA Analog output calibration is set by the F5 menu, mainly by the following two steps:

- Select the analog output calibrate mode
- The analog output calibrate process

Note 1: Before analog output calibration, weighing calibration must be done first, or the analog calibrate will be invalid.

Specific setting is as follows:

- (1) Set indicator to the Configuration mode (display shows "F 1")
- (2) Press **【TARE】** until the display shows "F 5" (See fig 5-1). Press **【ZERO】** and go to submenu of analog output mode setting, the display shows "F 5.1".
- (3) When display shows "F 5.1", press **【ZERO】** again, the display shows the analog value that need to be calibrated. Press **【TARE】** to select the calibrate mode. When F5.1=0, voltage mode is selected; when F5.1=1, current mode is selected.
- (4) Analog calibrate process:

Calibrate according to the selected mode. When 0-5V module (or 0-10V module) is selected, only 0-5V (or 0-10V) will be done.

When F5.1=0, voltage calibrate is in process.

- The display shows F 5.2, connect a voltmeter between the port mA-/VO and mA+/GND.
- When the scale is in zero, press **【ZERO】**, according to the display of voltmeter, press **【TARE】** to increase the voltage value (refer to Note 2 for details of trimming the voltage), press **【G/N】** to decrease the voltage value, until the voltmeter display shows 0V, press **【ZERO】** to save, 0V voltage calibration is finished. The display shows F5.3.
- When display shows F 5.3, put the full scale test weight onto the scale, press **【ZERO】**, according to the display of voltmeter, press **【TARE】** to increase the voltage value, press **【G/N】** to decrease the voltage value, until the voltmeter display shows 5V (or 10V), press **【ZERO】** to save, 5V (or 10V) voltage calibration is finished. The display shows F5.4.
- Voltage calibration is completed.

Note 2: Analog output adjustment method:

- **Rough adjustment: increase press 【SET】 + 【TARE】**
decrease press 【SET】 + 【G/N】
- **Precise adjustment: increase press 【TARE】**
decrease press 【G/N】

During the operation of analog output calibration, once enter into the menu, you can only exit out the menu by pressing 【ZERO】 and save, but can not exit by pressing 【SET】.

When F5.1=1, current calibrate is in process.

- Press [TARE] until display shows F5.4, connect an ammeter between the port mA-/VO and mA+/GND.

- When the scale is in zero, press **【ZERO】**, according to the display of ammeter, press **【TARE】** to increase the current value, press **【G/N】** to decrease the current value (refer to Note 2 for details of trimming the current), until the ammeter display shows 4mA, press **【ZERO】** to save, 4mA current calibration is finished, and go to next menu F5.5.
 - When display shows F 5.5, put the full scale test weight onto the scale, press **【ZERO】** to go to 20mA current calibrate process. According to the display of ammeter, press **【TARE】** to increase the current value, press **【G/N】** to decrease the current value, until the ammeter display shows 20mA, press **【ZERO】** to save, 20mA current calibration is finished. Display shows F6.1.
 - Current calibration is completed.
- (5) Press the **【SET】** twice to exit from the configuration mode.

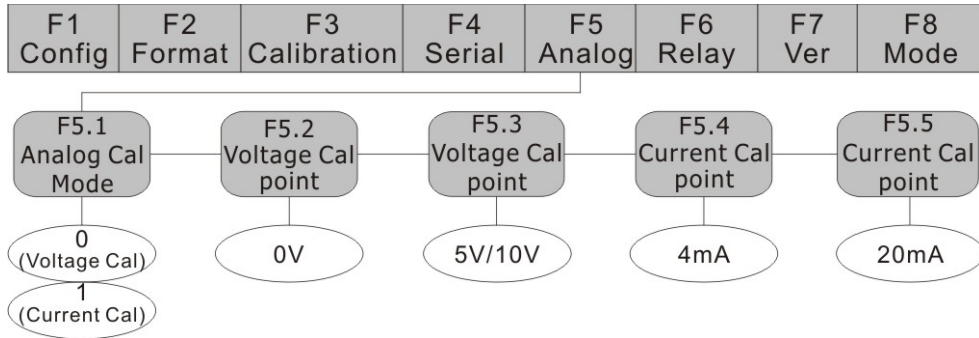

Fig. 5-1 Analog output calibrate menu

6. Relay Output Setup

There are two steps to set relay output:

- select the relay output mode
- set the relay control value

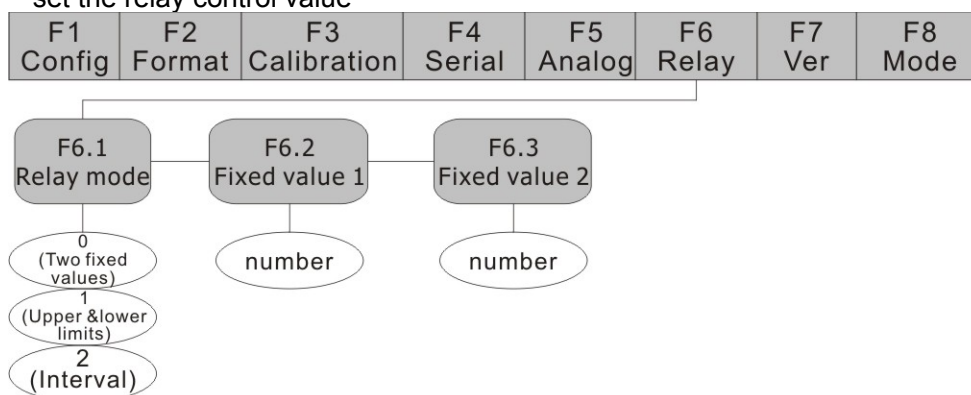

Fig.6-1 Relay Output Menu

Setup procedure:

- (1) Set indicator to the Configuration mode (display shows “F 1”)
- (2) Press **【TARE】** until display shows “F6” (see Fig. 6-1). Press **【ZERO】** to go to the Relay Output Menu. Display shows “F6.1”
- (3) When display shows “F6.1”, press **【ZERO】** again, indicator goes to the relay output menu. Press **【TARE】** to select the mode, the description of different modes is as follows:
 - Two fixed values (F6.1=0): If weight value (refer to Note 2) is lower than the value set in F6.2, OC1 (OC is abbreviation for open-collector) is off; if weight value is higher than or equal the value set in F6.2, OC1 is on. If weight value is lower than the value set in F6.3, OC2 is off; otherwise, OC2 is on. See Fig.6-2.
 - Upper and lower limits (F6.1=1): If weight value is lower than the value set in F6.2, OC1 is on; if weight value is higher than or equal the value set in F6.3, OC1 is off. If weight value is lower than value set in F6.3, OC2 is off, otherwise, OC2 is on. See Fig.6-3.
 - Interval (F6.1=2): If weight value is lower than the value set in F6.2, both OC1 and OC2 are off; if value set in $F6.2 \leq \text{weight value} \leq \text{value set in } F6.3$, OC1 is on and OC2 is off; if weight value is higher than or equal the value set in F6.3, OC1 is off and OC2 is on. See Fig.6-4.
- (4) When relay output mode is selected, press **【ZERO】** to save and go to the next menu, the display shows “F 6.2”.
- (5) When display shows “F 6.2”, press **【ZERO】** and display shows the value of lower limit setting. Edit the value according to editing procedures in Fig. 4-2. When complete, press **【ZERO】** to store the value and go to the next menu. Display shows “F 6.3”.

- (6) When display shows “F 6.3”, press 【ZERO】 and display shows the upper limit value setting. Edit the value according to Fig. 4-2. When complete, press 【ZERO】 to store the value and go to F7 Menu. Display shows “F 7.1”.
- (7) Press the 【SET】 twice to exit from the configuration mode.

Note 1: Must ensure F6.3 (P2) value > F6.2 (P1) value to give proper relay output

Note 2: Weight value is in gross weight and is according to the unit in F2.1 setting (Refer to F2 Menu in Section 3.2.2).

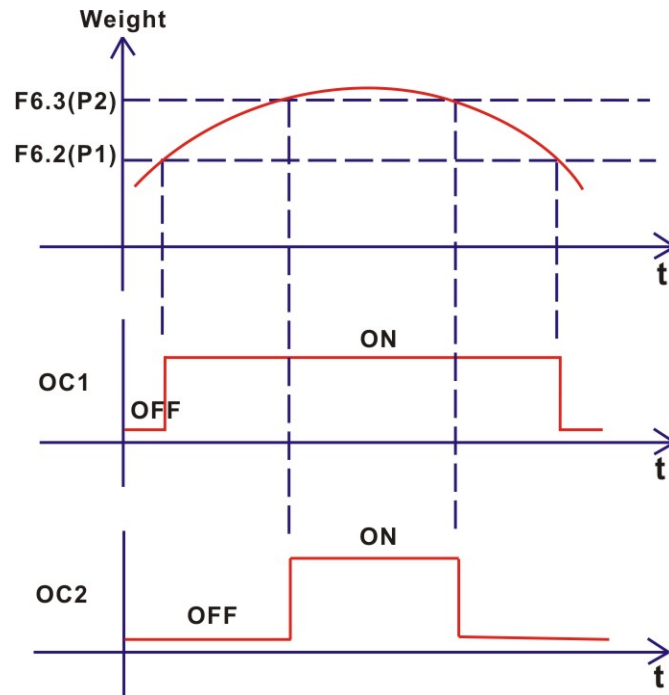

Fig.6-2 Relay output-Two fixed values

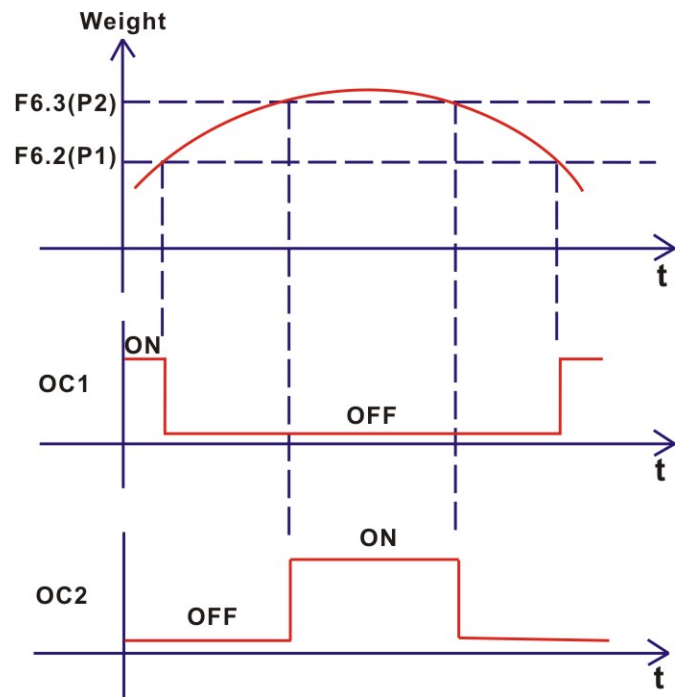

Fig.6-3 Relay Output- Upper and lower limits

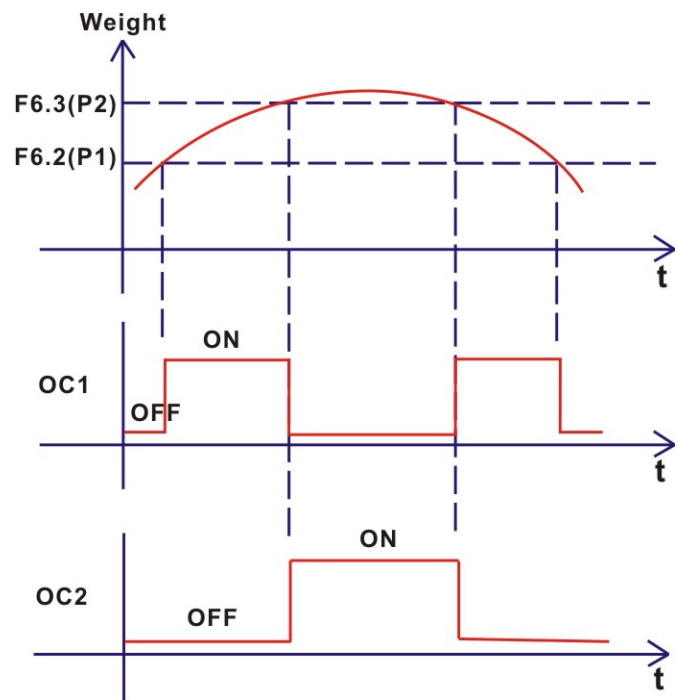

Fig.6-4 Relay Output- Interval

Circuit diagram of relay output interface:

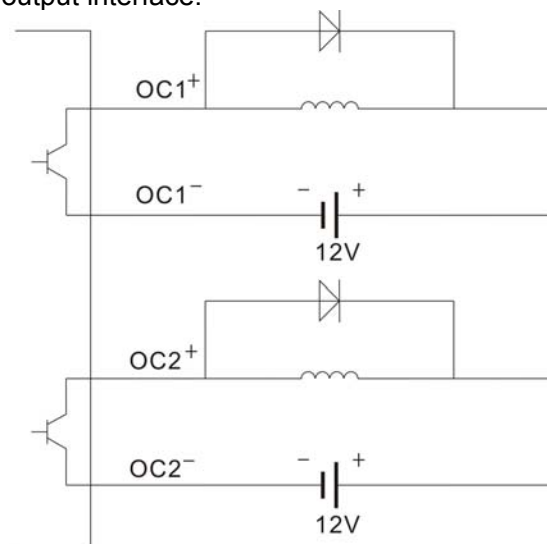

Fig. 6-5 Circuit diagram of relay output interface

7. Serial Communication

806DA indicator has the following two serial communication modes:

- Continuous transmission
- Transmission upon request (from an external PC)

Set up Baud, Bits, Parity, Mode and Test in F4 Menu.

Detailed Setup Procedure is as follow:

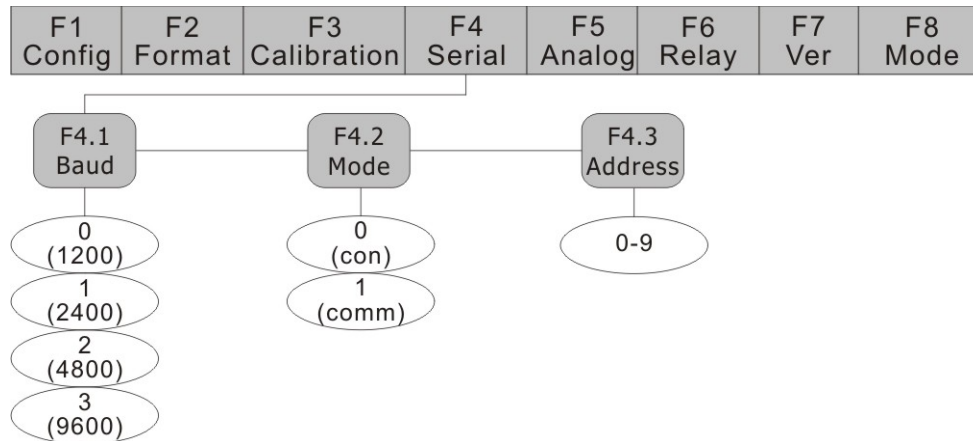

Fig.7-1 F4 Serial Communication Menu

7.1 Continuous Transmission

- (1) Set indicator to the Configuration mode (display shows "F 1")
- (2) Press **【TARE】** until display shows "F 4" (see Fig. 7-1). Press **【ZERO】** to go to F4 Menu. Display shows "F4.1".
- (3) When display shows "F 4.1", press **【TARE】** until display shows "F4.2".
- (4) When display shows "F 4.2", press **【ZERO】** to show serial communication code. Use **【TARE】** to set serial communication code to 0 (data transmitted continuously), press **【ZERO】** to save.
- (5) Press the **【SET】** twice to exit from the configuration mode. After selecting continuous transmission mode (F4.4=0), indicator transmits data continuously according to Fig. 7-2.

Note: Other items in F4 Menu are for Baud, Bits Test and etc. These parameters are suitable for continuous transmission and transmission upon request modes.

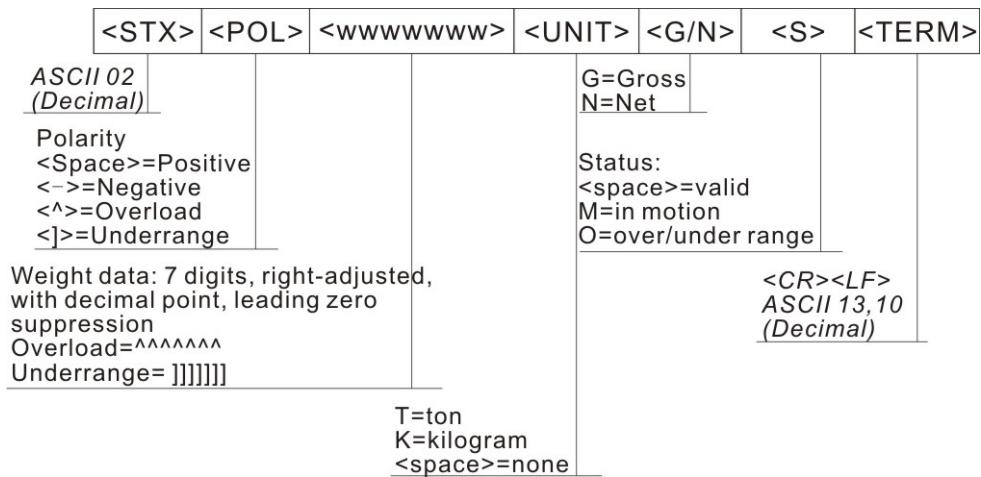

Fig.7-2 Format of Continuous Transmission

7.2 Transmission Upon Request

Set F4.2=1 as Section 7.1 above. After selecting the mode, indicator transmits data upon request according to Fig. 7-3 and Fig. 7-4.

When receiving a command, indicator sends "OK" after transmitting the requested data. Indicator sends "??" if it receives undefined or incorrect request or command.

7.2.1 Data Transmission Sequence

(1) Transmission Format from PC:

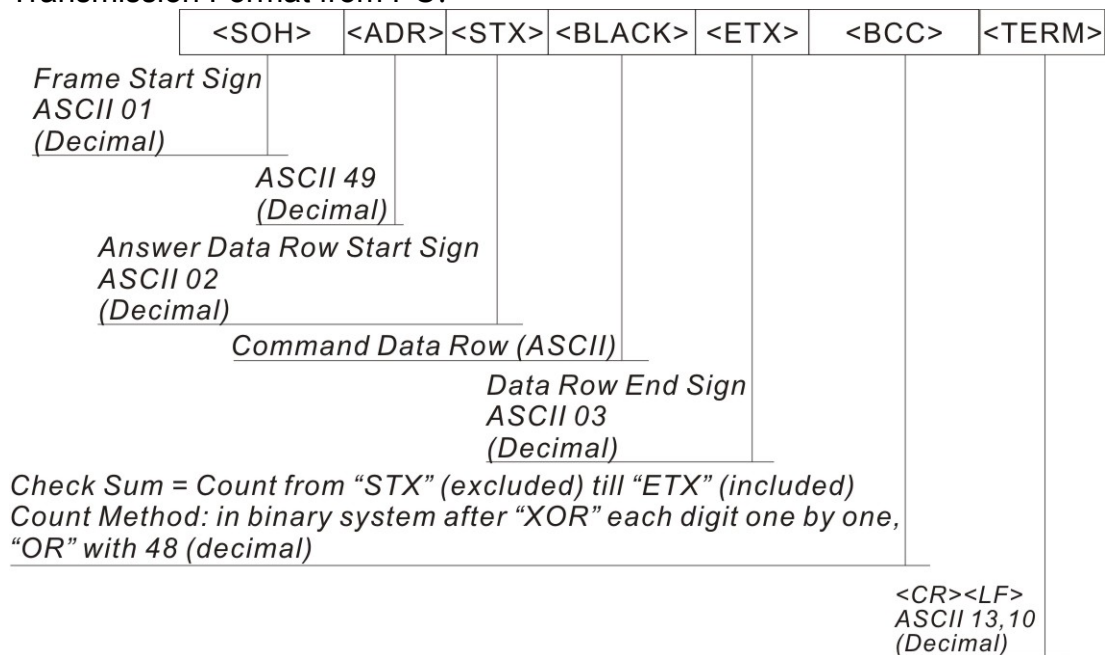

Fig.7-3 Transmission Format from PC

Example: Set BLOCK to "G" (which is 47H) in ASCII code. Inspection and BCC calculation are as follow:

ASCII	HEX	BCC	
G	47H	47H	
ETX	03H	44H	
	30H	74H	"OR" with 30H

(2) Respond Format from Indicator

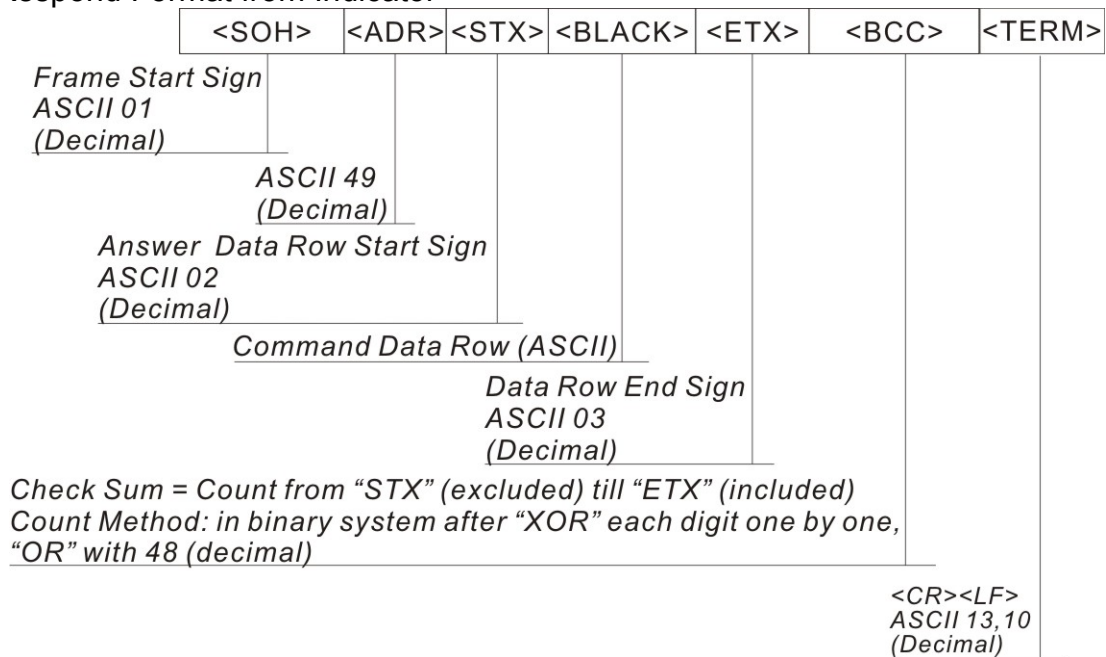

Fig.7-4 Respond Format from Indicator

7.2.2 Communication Command

7.2.2.1 Transmit Current Weight Value

Command data from PC<BLACK> Format: G (ASCII 71)

Response data from indicator<BLACK> Format see Fig. 7-5

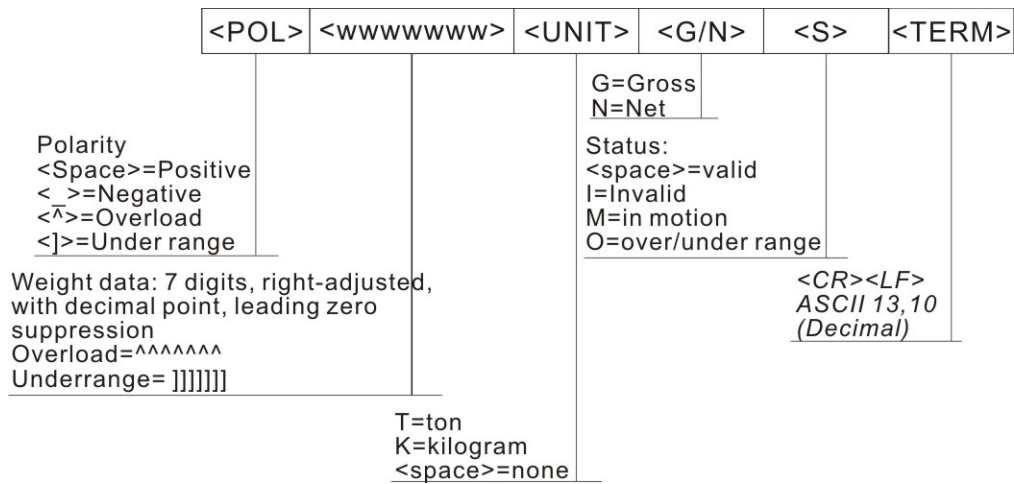

Fig.7-5 Respond to<BLACK>data after receiving G command

Example: PC receives weight data from indicator

PC sends: 01H, 31H, 02H, **47H**, 03H, 74H, 0DH, 0AH

Indicator responds: 01H, 31H, 02H, **20H, 20H, 20H, 20H, 31H, 30H, 37H, 32H, 4BH, 47H, 20H**, 03H, 3BH, 0DH, 0AH

Data received in gross weight 1072kg.

Note: The parameter of F4.3 must be set to 0~9 when the transmission address is 30H~39H, or the transmission won't be success.

7.2.2.2 Zero Scale

PC command data <BLACK> format : Z (ASCII 90)

Indicator receives correctly and responds data <BLACK> ="OK"

Example: PC sends command to indicator to zero scale

PC sends: 01H, 31H, 02H, **5AH**, 03H, 79H, ,0DH, 0AH

Indicator responds: 01H, 31H, 02H, **4FH, 4BH**, 03H, 37H ,0DH, 0AH

8. Appendix

8.1 Error Messages

When an error occurs, the message is shown on the indicator LED display. Error message codes are shown in Table 8-1.

Table 8-1 Error Message Code and Solution

Error Message	Description	Solution
Err1	Incorrect operating parameters	Check parameters according to Section 3
Err2	A/D exchange error	Check hardware by qualified personnel
Err3	Load cell input signal too high(>20mV)	Check the output signal of load cell
Err4	Load cell input signal too low(<-5mV)	Check the output signal of load cell
Err5	In weight calibration, zero weight value>full scale weight value	Recalibration, and make sure zero value<full scale value
OF	Load value>F1.5 Set value	Reduce load on scale

8.2 Software Version and Default Configuration Parameters

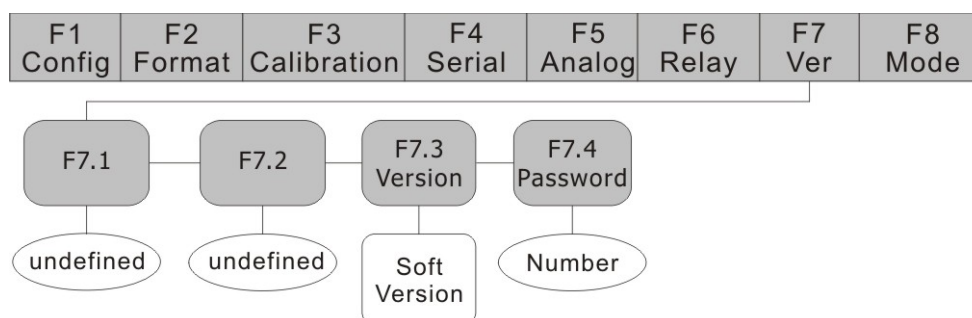

Fig.8-1 F7 (Ver) Menu

8.2.1 Find out software version of indicator

- (1) Set indicator to the Configuration mode (display shows “F 1”)
- (2) Press **【TARE】** until display shows “F 7” (see Fig. 8-1). Press **【ZERO】** to go to F7

Menu. Display shows “F 7.1”. Press **【TARE】** twice until display shows “F 7.3”.

- (3) When indicator shows “F 7.3”, press **【ZERO】** again, display shows the current software version “XX.XX”. Software version cannot be edited.
- (4) Press **【SET】** to return to F7.3 Menu. Display shows “F 7.3”.
- (5) Press the **【SET】** twice to exit from the configuration mode.

8.2.2 Restore Factory Setup Parameters

- (1) Set indicator to the Configuration mode (display shows “F 1”)
- (2) Press **【TARE】** until display shows “F 7” (see Fig. 8-1). Press **【ZERO】** to go to F7 Menu. Display shows “F 7.1”. Press **【TARE】** three times until display shows “F 7.4”.
- (3) When display shows “F 7.4”, press **【ZERO】**. Display shows a 6 digit code “100000”. Edit it to “680711” according to Fig. 4-2. Press **【ZERO】**.
- (4) There are two possible outcomes:
 - If input code is correct, display shows “Set ?” Then there are 2 options:
 - Press **【ZERO】** to restore parameters to factory setup and return to F8.1 Menu. Display shows “F 8.1”.
 - Press **【SET】**, give up restoring factory setup and return to F8.1 menu. Display shows “F 8.1”.
 - If input code is incorrect, display shows “Err”. Then there are 2 options:
 - Display shows 6 digits code in one second, return to step (3) as above, input the code again.
 - Press **【SET】**, give up restoring factory setup and return to F7.4 Menu. Display shows “F 7.4”.
- (5) When indicator shows “F 7.4”, press **【SET】** twice to exit from the configuration mode.

8.3 Technical Specifications

A/D sampling rate	7.5 times/sec~960times/sec selectable
internal resolution	24bits
non-linearity	$\leq 0.005\%F.S$
zero return	$\leq 0.1\mu V/^{\circ}C$
temperature effect	$\leq 5ppm/^{\circ}C$
full scale input signal	2~20mV
input signal sensitivity	0.4uV /d (minimum) 1.5uV/d (recommended)
zero scale range	$\pm 1.9\%FS, \pm 100\%FS$ selectable
tare range	0 ~ +100%FS
operating temperature	-10 $^{\circ}C$ ~ 40 $^{\circ}C$
operating humidity	$\leq 90\%$
power source	AC100-240V ($\pm 10\%$), 1A
relay current	DC 60V, 200mA
load cell bridge voltage	DC 5V can be connected to 16 cells of not less than 800 Ω or 8 cells of not less than 350 Ω

8.4 ASCII Code table

Control	ASCII	Dec	Hex	ASCII	Dec	Hex	ASCII	Dec	Hex	ASCII	Dec	Hex
Ctrl-@	NUL	00	00	space	32	20	@	64	40	`	96	60
Ctrl-A	SOH	01	01	!	33	21	A	65	41	a	97	61
Ctrl-B	STX	02	02	"	34	22	B	66	42	b	98	62
Ctrl-C	ETX	03	03	#	35	23	C	67	43	c	99	63
Ctrl-D	EOT	04	04	\$	36	24	D	68	44	d	100	64
Ctrl-E	ENQ	05	05	%	37	25	E	69	45	e	101	65
Ctrl-F	ACK	06	06	&	38	26	F	70	46	f	102	66
Ctrl-G	BEL	07	07	'	39	27	G	71	47	g	103	67
Ctrl-H	BS	08	08	(40	28	H	72	48	h	104	68
Ctrl-I	HT	09	09)	41	29	I	73	49	i	105	69
Ctrl-J	LF	10	0A	*	42	2A	J	74	4A	j	106	6A
Ctrl-K	VT	11	0B	+	43	2B	K	75	4B	k	107	6B
Ctrl-L	FF	12	0C	,	44	2C	L	76	4C	l	108	6C
Ctrl-M	CR	13	0D	-	45	2D	M	77	4D	m	109	6D
Ctrl-N	SO	14	0E	.	46	2E	N	78	4E	n	110	6E
Ctrl-O	SI	15	0F	/	47	2F	O	79	4F	o	111	6F
Ctrl-P	DLE	16	10	0	48	30	P	80	50	p	112	70
Ctrl-Q	DC1	17	11	1	49	31	Q	81	51	q	113	71
Ctrl-R	DC2	18	12	2	50	32	R	82	52	r	114	72
Ctrl-S	DC3	19	13	3	51	33	S	83	53	s	115	73
Ctrl-T	DC4	20	14	4	52	34	T	84	54	t	116	74
Ctrl-U	NAK	21	15	5	53	35	U	85	55	u	117	75
Ctrl-V	SYN	22	16	6	54	36	V	86	56	v	118	76
Ctrl-W	ETB	23	17	7	55	37	W	87	57	w	119	77
Ctrl-X	CAN	24	18	8	56	38	X	88	58	x	120	78
Ctrl-Y	EM	25	19	9	57	39	Y	89	59	y	121	79
Ctrl-Z	SUB	26	1A	:	58	3A	Z	90	5A	z	122	7A
Ctrl-[ESC	27	1B	;	59	3B	[91	5B	{	123	7B
Ctrl-\	FS	28	1C	<	60	3C	\	92	5C		124	7C
Ctrl-]	GS	29	1D	=	61	3D]	93	5D	}	125	7D
Ctrl-^	RS	30	1E	>	62	3E	^	94	5E	~	126	7E
Ctrl-_ Ctrl-~	US	31	1F	?	63	3F	_	95	5F	DEL	127	7F

Fig. 8-2 ASCII Code Tabel

8.5 806DA Display Characters

!	-	9	E	Q
"	. .	:	F	R
#	/	;	G	S
\$	0	<	H	T
%	1	=	I	U
&	2	>	J	V
'	3	?	K	W
(4	@	L	X
)	5	A	M	Y
*	6	B	N	Z
+	7	C	O	[
,	8	D	P	\

Fig. 8-3 Display Characters